

Simple Specials:



1	-XA0 to XA30	Change of rod end shape	P.1710
2	-XA0, 1, 2, 6, 7, 11, 17, 18	CUJ($\phi 6$ to $\phi 20$): Change of rod end shape	P.1714
3	-XA1, 2, 6, 7, 11, 17, 18	CQS/CQ2/RQ/CLQ($\phi 12$ to $\phi 25$): Change of rod end shape	P.1715
4	-XA1 to XA23/-XA26 to XA30	CQ2/RQ/CLQ($\phi 32$ to $\phi 100$)/CQ2 Large bore size($\phi 125$ to $\phi 200$): Change of rod end shape	P.1716
5	-XA1, 6, 7, 17, 18	MU($\phi 25$ to $\phi 63$): Change of rod end shape	P.1717-1
6	-XA1 to XA38	RSQ($\phi 12$ to $\phi 50$)/RSG($\phi 40, \phi 50$): Change of rod end shape	P.1718
7	-XA1, 6, 17, 21	MGP/MGQ: Change of guide rod end shape	P.1719
8	-XC14	Change of trunnion bracket mounting position	P.1720
9	-XC15	Change of tie-rod length	P.1722
10	-XC79	Tapped hole, drilled hole, pinned hole machined additionally	P.1723

How to Order When Combining Made-to-Order Specifications

How to order when combining two specifications: simple specials (XA□) and made-to-order common specifications (XB□, XC□).

■ How to Order Example: 1 (Enter the symbol in alphabetical order.)

CQ2B25 - 30D - **XA7B6**

Note) "X" of XB6 is not necessary.

● Made to Order

Symbol	Specifications
XA7	Change of rod end shape
XB6	Heat resistant cylinder

■ How to Order Example: 2 (Enter the symbol in numerical order when alphabetical letters are the same.)

CDQ2B25 - 30DZ - M9BW - **XC4C6**

Note) "X" of XC6 is not necessary.

● Made to Order

Symbol	Specifications
XC4	With heavy duty scraper
XC6	Made of stainless steel

* Please contact SMC for the availability of a desired combination of simple specials and made-to-order specifications or a combination of three or more made-to-order specifications.

Simple Specials: -XA0 to XA30: Change of Rod End Shape

These changes are dealt with Simple Specials System. Refer to the front matter pages for details.

1 Change of Rod End Shape

Applicable Series

Series		Action	Symbol for change of rod end shape	Note
CJP2	Pin cylinder	CJP2	Double acting, Single rod XA0/1/10/11	ø6, ø10, ø16
CJ2	Standard type	CJ2-Z	Double acting, Single rod XA0/1/10/11	Available with air cushion
		CJ2W-Z	Double acting, Double rod XA0/1/10/11	Available with air cushion
	Non-rotating rod type	CJ2K-Z	Double acting, Single rod XA0/1/10/11	
			Single acting (Spring return/extend) XA0/1/10/11	
	With speed controller type	CJ2Z-Z	Double acting, Single rod XA0/1/10/11	
		CJ2ZW-Z	Double acting, Double rod XA0/1/10/11	
	Direct mount type	CJ2RA-Z	Double acting, Single rod XA0/1/10/11	
			Single acting (Spring return/extend) XA0/1/10/11	
	Non-rotating rod, Direct mount type	CJ2RK-Z	Double acting, Single rod XA0/1/10/11	
		Single acting (Spring return/extend) XA0/1/10/11		
Smooth cylinder	CJ2Y-Z	Double acting, Single rod XA0/1/10/11		
CM2	Standard type	CM2-Z	Double acting, Single rod XA0 to 30	
			Single acting (Spring return/extend) XA0 to 30	
		CM2W-Z	Double acting, Double rod XA0 to 30	
	Standard type (Air-hydro type)	CM2H	Double acting, Single rod XA0 to 30	
		CM2WH	Double acting, Double rod XA0 to 30	
	Non-rotating rod type	CM2K-Z	Double acting, Single rod XA0,1,6,10,11,13,14,17,19,21	
	Direct mount type	CM2R-Z	Double acting, Single rod XA0 to 30	
	Non-rotating rod, Direct mount type	CM2RK-Z	Double acting, Single rod XA0,1,6,10,11,13,14,17,19,21	
	Centralized piping type	CM2□□P	Double acting, Single rod XA0 to 30	
End lock cylinder	CBM2	Double acting, Single rod XA0 to 30		
Smooth cylinder	CM2Y-Z	Double acting, Single rod XA0 to 30		
CG1	Standard type	CG1-Z	Double acting, Single rod XA0 to 30	
			Double acting, Double rod XA0 to 30	
	Standard type (Air-hydro type)	CG1H-Z	Double acting, Single rod XA0 to 30	
	Non-rotating rod type	CG1K-Z	Double acting, Single rod XA0 to 30	
	Direct mount type	CG1R-Z	Double acting, Single rod XA0 to 30	
	End lock cylinder	CBG1	Double acting, Single rod XA0 to 30	
Smooth cylinder	CG1Y-Z	Double acting, Single rod XA0 to 30		
CG3	Standard type	CG3	Double acting, Single rod XA0 to 30	

Simple Specials: Change of Rod End Shape

Symbol

-XA0 to XA30

Series		Action	Symbol for change of rod end shape	Note	
MB	Standard type	MB-Z	Double acting, Single rod	XA0 to 30	
		MBW-Z	Double acting, Double rod	XA0 to 30	
	Non-rotating rod type	MBK-Z	Double acting, Single rod	XA0/1/6/10/11/13/14/17/19/21	
	With end lock type	MBB	Double acting, Single rod	XA0 to 30	
MB1	Smooth cylinder	MBY-Z	Double acting, Single rod	XA0 to 30	
	Standard type	MB1-Z	Double acting, Single rod	XA0 to 30	
		MB1W-Z	Double acting, Double rod	XA0 to 30	
CA2	Non-rotating rod type	MB1K-Z	Double acting, Single rod	XA0/1/6/10/11/13/14/17/19/21	
	Standard type	CA2-Z	Double acting, Single rod	XA0 to 30	
		CA2W-Z	Double acting, Double rod	XA0 to 30	
	Non-rotating rod type	CA2K	Double acting, Single rod	XA0/1/6/10/11/13/14/17/19/21	ø40 to ø63
	Standard type (Air-hydro type)	CA2□H	Double acting, Single rod	XA1/3/5 to 8/10/11/13 to 23/26 to 30	
CS1	End lock cylinder	CBA2	Double acting, Single rod	XA0 to 30	
	Smooth cylinder	CA2Y-Z	Double acting, Single rod	XA0 to 30	
	Standard type	CS1	Double acting, Single rod	XA0 to 30	
CS2	Low friction type	CS1W	Double acting, Double rod	XA0 to 30	
		CS1□Q	Double acting, Single rod	XA0 to 30	
CJ5	Standard type	CS2	Double acting, Single rod	XA0 to 30	
		CS2W	Double acting, Double rod	XA0 to 30	
CG5	Smooth cylinder	CS2Y	Double acting, Single rod	XA0 to 30	
	Stainless steel cylinder	CJ5-S	Double acting, Single rod	XA0/1/10/11	
CN MN CL	Cylinder with lock	CG5-S	Double acting, Single rod	XA0 to 30	
		CNG	Double acting, Single rod	XA0 to 30	
		MWB	Double acting, Single rod	XA0 to 30	
		MNB	Double acting, Single rod	XA0 to 30	
		CNA2	Double acting, Single rod	XA0 to 30	
		CNS	Double acting, Single rod	XA0 to 30	
CL	Fine lock cylinder	CLS	Double acting, Single rod	XA0 to 30	
		CLJ2	Double acting, Single rod	XA0/1/10/11	
		CLM2	Double acting, Single rod	XA0 to 30	
CL	Locked-up cylinder	CLG1	Double acting, Single rod	XA0 to 30	
		CL1	Double acting, Single rod	XA0 to 30	
CV	Valve mounted cylinder	CVJ5	Double acting, Single rod	XA0/1/10/11	
		CVJ3	Single acting (Spring return/extend)	XA0/1/10/11	
		CVM5	Double acting, Single rod	XA0 to 30	
		CVM3	Single acting (Spring return/extend)	XA0 to 30	
		CV3	Double acting, Single rod	XA0 to 30	
		CVS1	Double acting, Single rod	XA0 to 30	
		CVM5K	Double acting, Single rod	XA0/1/6/10/11/13/14/17/19/21	
		CVM3K	Single acting (Spring return/extend)	XA0/1/6/10/11/13/14/17/19/21	
		CV3K	Double acting, Single rod	XA0/1/6/10/11/13/14/17/19/21	ø40 to ø63
		CVS1K	Double acting, Single rod	XA0/1/6/10/11/13/14/17/19/21	ø40 to ø63

-XC

Simple Specials: -XA0 to XA30: Change of Rod End Shape

These changes are dealt with Simple Specials System. Refer to the front matter pages for details.

⚠ Precautions

- SMC will make appropriate arrangements if no dimension, tolerance, or finish instructions are given in the diagram.
- Standard dimensions marked with "*" will be as follows to the rod diameter (D).
 $D \leq 6 \rightarrow D - 1 \text{ mm}$, $6 < D \leq 25 \rightarrow D - 2 \text{ mm}$, $D > 25 \rightarrow D - 4 \text{ mm}$
- In the case of double rod type and single acting retraction type, enter the dimensions when the rod is retracted.
- The same shape as the standard type is "A0".
 (The specifications of A0 are that only dimensions A and H are changed from the standard type.)

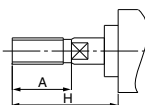
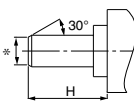
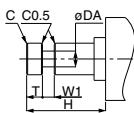
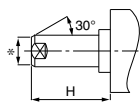
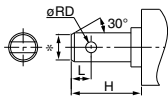
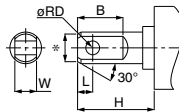
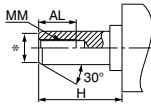
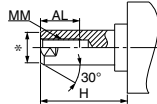
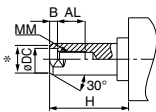
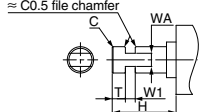
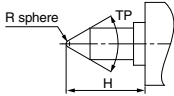
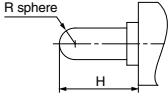
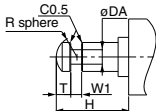
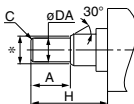
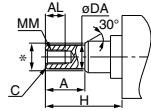
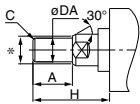
Symbol: A0 	Symbol: A1 	Symbol: A2 	Symbol: A3 
Symbol: A4 	Symbol: A5 	Symbol: A6 	Symbol: A7 
Symbol: A8 	Symbol: A9 	Symbol: A10 	Symbol: A11 
Symbol: A12 	Symbol: A13 	Symbol: A14 	Symbol: A15 

Simple Specials: Change of Rod End Shape

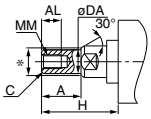
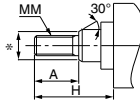
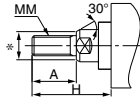
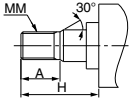
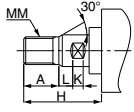
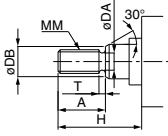
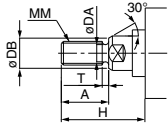
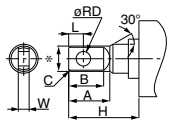
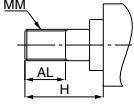
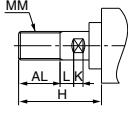
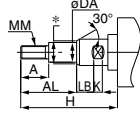
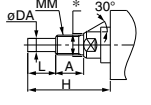
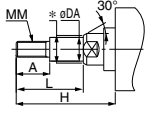
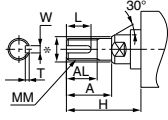
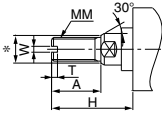
<p>Symbol: A16</p> 	<p>Symbol: A17</p> 	<p>Symbol: A18</p> 	<p>Symbol: A19</p> 
<p>Symbol: A20</p> 	<p>Symbol: A21</p> 	<p>Symbol: A22</p> 	<p>Symbol: A23</p> 
<p>Symbol: A24</p> 	<p>Symbol: A25</p> 	<p>Symbol: A26</p> 	<p>Symbol: A27</p> 
<p>Symbol: A28</p> 	<p>Symbol: A29</p> 	<p>Symbol: A30</p> 	

Simple Specials: XA1/2/6/7/11/17/18: Change of Rod End Shape

These changes are dealt with Simple Specials System. Refer to the front matter pages for details.

Symbol

2 CUJ (ø6 to ø20): Change of Rod End Shape

-XA1/2/6/7/11/17/18

Applicable Series

Series			Action	Symbol for change of rod end shape
CUJ	Standard type	CUJ	Double acting, Single rod	ø6 to ø10 XA1/XA10/XA11/XA18 ø12 to ø20 XA1/XA2/XA6/XA7/XA11 XA17/XA18

⚠ Precautions

- SMC will make appropriate arrangements if no dimension, tolerance, or finish instructions are given in the diagram.
- Standard dimensions marked with "*" will be as follows to the rod diameter (D).
Enter any special dimension you desire.
ø6 to ø16 → D - 1 mm ø20 → D - 2 mm
- It is impossible to manufacture when XA17 and XA18 are the same male thread diameter as the piston rod external diameter.
- Please contact SMC separately for the piston rod end pattern part numbers other than the table above and the cases other than the manufacturing conditions.

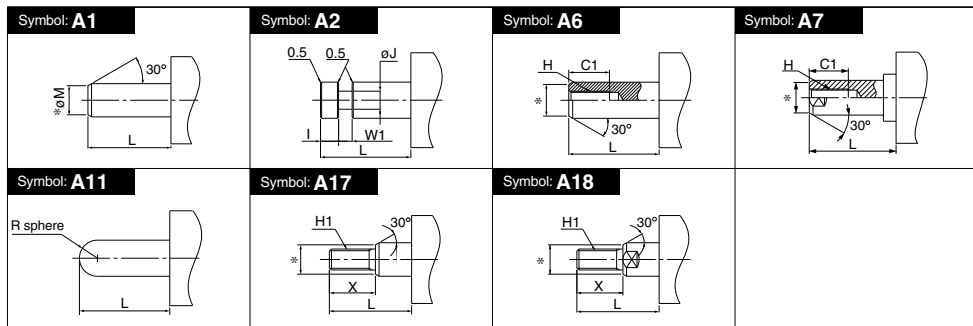

Conditions of Manufacture

ø6 to ø10

Symbol	Conditions of Manufacture
XA1	ø6 øM: 3.5 mm or less
	ø8 øM: 4.5 mm or less
	ø10 øM: 5 mm or less
XA11	ø6 SR2 mm or more
	ø8 SR2.5 mm or more
	ø10 SR3 mm or more
XA18	ø6 H1: M3 only, X: 48 mm or less
	ø8 H1: M4 only, X: 48 mm or less
	ø10 H1: M5 only, X: 48 mm or less

ø12 to ø20

Symbol	Conditions of Manufacture
XA1	ø12 øM: 3 to 5.4 mm
	ø16 øM: 3 to 7 mm
	ø20 øM: 4 to 8 mm
XA2	ø12 øJ: 4 mm or more, øI: 6 mm or less
	ø16 øJ: 4 mm or more, øI: 6 mm or less
	ø20 øJ: 5 mm or more, øI: 11 mm or less
XA6	ø12 H: M4 or less
	ø16 H: M6 or less
	ø20 H: M6 or less
XA7	ø12 H: M4 or less
	ø16 H: M5 or less
	ø20 H: M6 or less

Symbol	Conditions of Manufacture
XA11	ø12 SR3 mm only
	ø16 SR4 mm only
	ø20 SR5 mm only
XA17	ø12 H1: M5 or more, X: 20 mm or less
	ø16 H1: M6 or more, X: 22.5 mm or less
	ø20 H1: M8 or more, X: 26.5 mm or less
XA18	ø12 H1: M5 or more, X: 20 mm or less
	ø16 H1: M6 or more, X: 22.5 mm or less
	ø20 H1: M8 or more, X: 26.5 mm or less

Simple Specials: -XA1/2/6/7/11/17/18: Change of Rod End Shape

These changes are dealt with Simple Specials System. Refer to the front matter pages for details.

Symbol

3 CQS/CQ2/RQ/CLQ (ø12 to ø25): Change of Rod End Shape

-XA1/2/6/7/11/17/18

Applicable Series

Series		Action	Symbol for change of rod end shape
CQS	Standard type	CQS Double acting, Single rod Spring acting (Spring return) ^(Note)	XA1/XA2/XA6 XA7/XA11
		CQSW Double acting, Double rod	
	Long stroke	CQS Double acting, Single rod	XA17/XA18
	Anti-lateral load	CQS-S Double acting, Single rod	
		CQSK Double acting, Single rod	XA1/XA2 XA6/XA11
Non-rotating rod type	CQSK Double acting, Double rod (Non-rotating side)		
	CQSKW Double acting, Double rod (Round rod side)	XA1/XA2/XA6/XA7 XA11/XA17/XA18	

Note) Single acting, spring extend type is available as a special order.

⚠ Precautions

- SMC will make appropriate arrangements if no dimension, tolerance, or finish instructions are given in the diagram.
- Standard dimensions marked with "*" will be as follows to the rod diameter (D). Enter any special dimension you desire.
ø12, ø16 → D - 1 mm ø20, ø25 → D - 2 mm
- In the case of double rod, fill in the dimension when the rod is retracted.
- It is impossible to manufacture when XA17 and XA18 are the same male thread diameter as the piston rod external diameter.
- Please contact SMC separately for the piston rod end pattern part numbers other than the table above and the cases other than the manufacturing conditions.

Series		Action	Symbol for change of rod end shape
CQ2 (ø12 to ø25)	Standard type	CQ2-Z Double acting, Single rod Spring acting (Spring return)	XA1/XA2/XA6 XA7/XA11 XA17/XA18
		CQ2W-Z Double acting, Double rod	
	Axial piping type (Centralized piping type)	CQP2 Double acting, Single rod Single acting (Spring return)	
		CQ2K-Z Double acting, Single rod	XA1/XA2/XA6 XA11/XA17
	Non-rotating rod type	CQ2KW-Z Double acting, Double rod (Non-rotating side)	
CQ2KW-Z Double acting, Double rod (Round rod side)		XA1/XA2/XA6/XA7 XA11/XA17/XA18	
RQ Standard type	RQ Double acting, Single rod	XA1/XA2/XA6/XA7 XA11/XA17/XA18	
CLQ (ø20 to ø25) With lock	CLQ Double acting, Single rod	XA1/XA2/XA6/XA7 XA11/XA17/XA18	

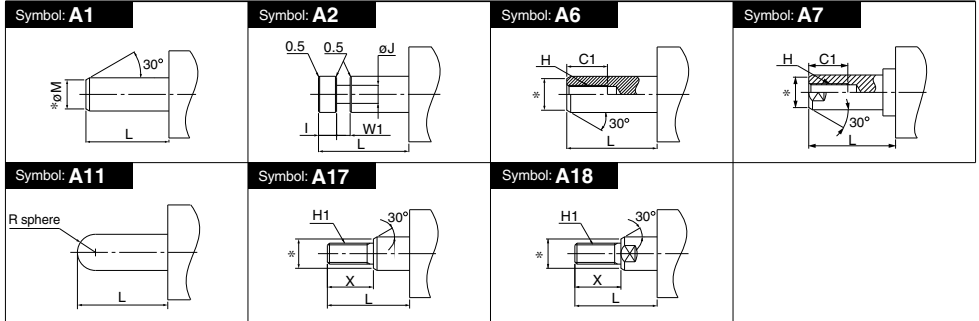

Conditions of Manufacture

Change of rod end shape/Symbol	Single rod type		Double rod type	
	For ø12	For ø16, ø20, ø25	For ø12	For ø16, ø20, ø25
XA1	ø12	øM: 3 mm or more 5 mm or less	øM: ø5 mm or less	
	ø16	øM: 3 mm or more 7 mm or less	øM: ø7 mm or less	
	ø20	øM: 4 mm or more 8 mm or less	øM: ø8 mm or less	
	ø25	øM: 4 mm or more 10 mm or less	øM: ø10 mm or less	
XA2	For ø12	øJ: 4 mm or more, W1: 6 mm or less	øJ: 3 mm or more, W1: 6 mm or less	
	ø16	øJ: 4 mm or more, W1: 6 mm or less	øJ: 4 mm or more, W1: 6 mm or less	
	ø20	øJ: 5 mm or more, W1: 11 mm or less	øJ: 5 mm or more, W1: 11 mm or less	
	ø25	øJ: 6 mm or more, W1: 13 mm or less	øJ: 6 mm or more, W1: 13 mm or less	
XA6	For ø12	H: M4 or less	H: M4 or less	
	ø16	H: M6 or less	H: M6 or less	
	ø20	H: M6 or less	H: M6 or less	
	ø25	H: M8 or less	H: M8 or less	
XA7	For ø12	H: M4 or less	H: M4 or less	
	ø16	H: M5 or less	H: M5 or less	
	ø20	H: M6 or less	H: M6 or less	
	ø25	H: M8 or less	H: M8 or less	

Change of rod end shape/Symbol	Single rod type		Double rod type	
	For ø12	For ø16, ø20, ø25	For ø12	For ø16, ø20, ø25
XA11	For ø12	SR3 mm only	SR3 mm or more	
	ø16	SR4 mm only	SR4 mm or more	
	ø20	SR5 mm only	SR5 mm or more	
	ø25	SR6 mm only	SR6 mm or more	
XA17	For ø12	H: M5 or more, X: 20 mm or less	H: M5 or less	
	ø16	H: M6 or more, X: 22.5 mm or less	H: M6 or less	
	ø20	H: M8 or more, X: 26.5 mm or less	H: M8 or less	
	ø25	H: M10 or more, X: 33 mm or less	H: M10 or less	
XA18	For ø12	H: M5 or more, X: 20 mm or less	H: M5 or less	
	ø16	H: M6 or more, X: 22.5 mm or less	H: M6 or less	
	ø20	H: M8 or more, X: 26.5 mm or less	H: M8 or less	
	ø25	H: M10 or more, X: 33 mm or less	H: M10 or less	

Simple Specials: -XA1 to XA23/-XA26 to XA30: Change of Rod End Shape

These changes are dealt with Simple Specials System. Refer to the front matter pages for details.

4 CQ2/RQ/CLQ (ø32 to ø100)/CQ2 large bore size (ø125 to ø200) : Change of Rod End Shape

Applicable Series

Series		Action	Symbol for change of rod end shape
CQ2	Standard type	CQ2-Z	XA1 to 23 XA26 to 30
		CQ2W-Z	
	Axial piping type (Centralized piping type)	CQP2	
		CQ2-S-Z	
	Anti-lateral load	CQ2-Z	
	Long stroke	CQ2K-Z	
Non-rotating rod type	CQ2K-Z	XA1/XA2/XA6 XA10 to XA14 XA19/XA21	
	CQ2KW-Z	XA1 to 23 XA26 to 30	

Note) Single acting, spring extend type is available as a special order.

Series		Action	Symbol for change of rod end shape
CQ2	Large bore size ø125 to ø200	CQ2-Z	XA1 to 23 XA26 to 30
		CQ2W-Z	
RQ	Standard type	RQ	XA1 to 23 XA26 to 30
CLQ	With lock	CLQ	XA1 to 23 XA26 to 30

⚠ Precautions

- SMC will make appropriate arrangements if no dimension, tolerance, or finish instructions are given in the diagram.
- Standard dimensions marked with "*" will be as follows to the rod diameter (D).
Enter any special dimension you desire.
D – 2 mm
- In the case of double rod, fill in the dimension when the rod is retracted.

<p>Symbol: A1</p>	<p>Symbol: A2</p>	<p>Symbol: A3</p>	<p>Symbol: A4</p>
<p>Symbol: A5</p>	<p>Symbol: A6</p>	<p>Symbol: A7</p>	<p>Symbol: A8</p>
<p>Symbol: A9</p>	<p>Symbol: A10</p>	<p>Symbol: A11</p>	<p>Symbol: A12</p>

Simple Specials: Change of Rod End Shape

Symbol

-XA1 to XA23/-XA26 to XA30

<p>Symbol: A13</p>	<p>Symbol: A14</p>	<p>Symbol: A15</p>	<p>Symbol: A16</p>
<p>Symbol: A17</p>	<p>Symbol: A18</p>	<p>Symbol: A19</p>	<p>Symbol: A20</p>
<p>Symbol: A21</p>	<p>Symbol: A22</p>	<p>Symbol: A23</p>	<p>Symbol: A26</p>
<p>Symbol: A27</p>	<p>Symbol: A28</p>	<p>Symbol: A29</p>	<p>Symbol: A30</p>

-X□

Simple Specials: -XA1/6/7/17/18: Change of Rod End Shape

These changes are dealt with Simple Specials System. Refer to the front matter pages for details.

5 MU (ø25 to ø63): Change of Rod End Shape

Symbol

-XA1/6/7/17/18

Applicable Series

Series			Action	Symbol for change of rod end shape
MU	Standard type	MU-Z	Double acting, Single rod	XA1, XA6, XA7, XA17, XA18

⚠ Precautions

- 1) SMC will make appropriate arrangements if no dimension, tolerance, or finish instructions are given in the diagram.
- 2) Standard dimensions marked with "*" will be $D - 2$ mm to the rod diameter (D).
- 3) The parts of XA1 marked * (øM) can be changed, so specify the diameter within the øM manufacturing conditions in the Conditions of Manufacture below.
- 4) The parts of XA6, XA7, XA17, and XA18 marked * cannot be changed.
- 5) Please contact SMC separately for the piston rod end pattern part numbers other than the table above and the cases other than the manufacturing conditions.

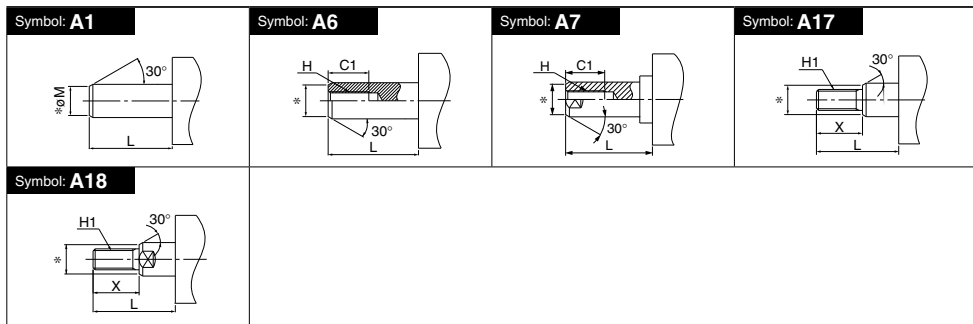

Conditions of Manufacture

Symbol	Size	Conditions of manufacture	
XA1	25	øM: ø5 to ø10	
	32	øM: ø7 to ø12	
	40	øM: ø8 to ø14	
	50	øM: ø11 to ø18	
XA6	25	H: M8 or less	
	32	H: M10 or less	
	40	H: M10 or less	
	50	H: M12 or less	
XA7	25	H: M8 or less	
	32	H: M10 or less	
	40	H: M10 or less	
	50	H: M12 or less	
XA17	25	H: M8 or less	
	32	H: M10 or less	
	40	H: M12 or less	
	50	H: M14 or less	
XA18	25	H: M8 or less	
	32	H: M10 or less	
	40	H: M12 or less	
	50	H: M14 or less	
XA18	63	H: M16 or less	
	XA18	63	H: M18 or less

Symbol	Size	Conditions of manufacture	
		H1	X
XA17	25	M6	24 or less
		M8	70 or less
		M10	90 or less
		M12	100 or less
	32	M8	40 or less
		M10	80 or less
		M12	100 or less
		M14	120 or less
40	M10	50 or less	
	M12	100 or less	
	M14	120 or less	
	M16	130 or less	
50	M18	160 or less	
	M14	60 or less	
	M16	110 or less	
	M18	160 or less	

Symbol	Size	Conditions of manufacture	
		H1	X
XA18	25	M6	24 or less
		M8	70 or less
		M10	90 or less
		M12	100 or less
	32	M8	40 or less
		M10	80 or less
		M12	100 or less
		M14	120 or less
40	M10	50 or less	
	M12	100 or less	
	M14	120 or less	
	M16	130 or less	
50	M18	160 or less	
	M14	60 or less	
	M16	110 or less	
	M18	160 or less	

Simple Specials -XA1 to XA38: Change of Rod End Shape

These changes are dealt with Simple Specials System. Refer to the front matter pages for details.

6 RSQ (ø12 to ø50)/RSG (ø40, ø50): Change of Rod End Shape

Symbol -XA1 to XA38

Applicable Series

Series		Action	Symbol for change of rod end shape
RSQ	Stopper cylinder Fixed mounting height	RSQ-Z	Double acting
		RSQ-Z ^(Note)	Double acting with spring loaded
	Stopper cylinder Adjustable mounting height	RSG	Double acting
		RSG	Double acting with spring loaded
		Single acting	

(Note) Size ø12 is the same shape as the current product (RSQ).

- For chamfered type (XA35 to XA38), make the H dimension to be equal to or less than the values on Table (1). (For the case with larger dimension than Table (1), it will be made-to-order separately.)

Table (1)

Bore size (mm)	H (mm)
ø12, ø16	40
ø20, ø32	63
ø40, ø50	83

⚠ Precautions

- SMC will make appropriate arrangements if no dimension, tolerance, or finish instructions are given in the diagram.
- Standard dimensions marked with "*" will be D - 2 mm to the rod diameter (D).
Enter any special dimension you desire.
- The following diagram shows piston rod at spring extend.

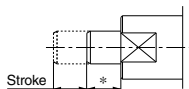

For the lengthwise dimension, enter the amount that you wish to add to the standard dimension.

(If the length is the same for the standard type, * in the figure on the left becomes 0.)

Round Bar

Symbol: A1 	Symbol: A3 	Symbol: A6 	Symbol: A7
Symbol: A8 	Symbol: A10 	Symbol: A11 	Symbol: A13
Symbol: A17 	Symbol: A18 	Symbol: A19 	Symbol: A32
Symbol: A33 	Symbol: A34 		

Chamfered Type

Symbol: A35 	Symbol: A36 	Symbol: A37 	Symbol: A38
------------------------	------------------------	------------------------	------------------------

Simple Specials: -XA1/6/17/21: Change of Guide Rod End Shape

These changes are dealt with Simple Specials System. Refer to the front matter pages for details.

7 MGP/MGQ: Change of Guide Rod End Shape

Symbol

-XA1/6/17/21

Applicable Series

Series		Action	Symbol for change of rod end shape	
MGP	Standard type	MGPM-Z	Slide bearing	XA1, 6, 17, 21
		MGPL-Z	Ball bushing bearing	XA1, 6
	With air cushion	MGPA-Z	Slide bearing	XA1, 6, 17, 21
		MGPM-AZ	Slide bearing	XA1, 6, 17, 21
		MGPL-AZ	Ball bushing bearing	XA1, 6
		MGPA-AZ	Ball bushing bearing	XA1, 6
MLGP	With lock	MLGPM	Slide bearing	XA1, 6, 17, 21
		MLGPL	Ball bushing bearing	XA1, 6
MGQ	Standard type	MGQM	Slide bearing	XA1, 6, 17, 21
		MGQL	Ball bushing bearing	XA1, 6
MVGQ	With valve	MVGQM	Slide bearing	XA1, 6, 17, 21
		MVGQL	Ball bushing bearing	XA1, 6

* For MGP, this is only applicable for the standard products (Basic type, With air cushion).

⚠ Precautions

- Ensure that the cylinder's overall length should not exceed the allowable overall length. In the case of exceeding the allowable overall length, it will be available as specials.
- In fig. (1) and (2) shown below, E' dimension cannot be set to less than E dimension of the standard product. Confirm by referring to the catalog.
- SMC will make appropriate arrangements if no dimension, tolerance, or finish instructions are given in the diagram.
- When the chamfering of the guide rod end is 30°, the * dimension is the guide rod diameter (D) - 2 mm. When the chamfering of the guide rod end is C0.5, the * dimension is the guide rod diameter (D) - 1 mm.

Bore size (mm)	Allowable overall length of cylinder (mm)
12, 16	345
20 to 32	540
40 to 63	561
80, 100	603

Fig. (1) For XA1, XA6 Fig. (2) For XA17, XA21

Guide Rod End Shape Pattern

<p>-XA1</p> <p>(Standard body dimensions)</p> <p>Note) For MGP-(A)Z and ball bushing type, the chamfering of the guide rod end is not 30°, but C0.5.</p>	<p>-XA6</p> <p>(Standard body dimensions)</p> <p>Note) For MGP-(A)Z and ball bushing type, the chamfering of the guide rod end is not 30°, but C0.5.</p>
<p>-XA17</p> <p>(Standard body dimensions)</p>	<p>-XA21</p> <p>(Standard body dimensions)</p>

Simple Specials: -XC14: Change of Trunnion Bracket Mounting Position

These changes are dealt with Simple Specials System. Refer to the front matter pages for details.

8 Change of Trunnion Bracket Mounting Position

Note

The position for mounting the trunnion pivot bracket on the cylinder can be moved from the standard mounting position to any desired position.

Series	Description	Model	Action	
MB	Standard type	MB-Z	Double acting, Single rod	
		MBW-Z	Double acting, Double rod	
	Non-rotating rod type	MBK-Z	Double acting, Single rod	
	End lock cylinder	MBB	Double acting, Single rod	
	Smooth cylinder	MBY-Z	Double acting, Single rod	
CA2	Standard type	CA2-Z	Double acting, Single rod	
		CA2W-Z	Double acting, Double rod	
	Non-rotating rod type	CA2K	Double acting, Single rod	Applicable to ø40 to ø63
		CA2KW	Double acting, Double rod	Applicable to ø40 to ø63
	End lock cylinder	CBA2	Double acting, Single rod	
	Air-hydro cylinder	CA2H	Double acting, Single rod	
Smooth cylinder	CA2Y-Z	Double acting, Single rod		
CS1	Standard type	CS1	Double acting, Double rod	
		CS1W	Double acting, Single rod	
	Low friction type	CS1□Q	Double acting, Single rod	
CS2	Standard type	CS2	Double acting, Double rod	
		CS2W	Double acting, Single rod	
	Smooth cylinder	CS2Y	Double acting, Single rod	
CNA2	Cylinder with lock	CNA2	Double acting, Double rod	
		CNA2W	Double acting, Single rod	
CNS	Cylinder with lock	CNS	Double acting, Single rod	
CLS		Double acting, Single rod		
CL1	Lock-up cylinder	CL1	Double acting, Single rod	Applicable to ø40 to ø100
CVS1	Valve mounted cylinder	CVS1	Double acting, Single rod	
		CVS1K	Double acting, Single rod	Applicable to ø40 to ø63

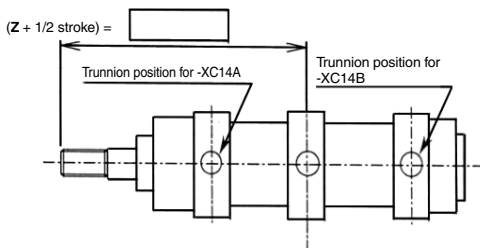

⚠ Precautions

- Specify "Z + 1/2 stroke" in the case the trunnion bracket position is not -XC14A, B or trunnion is not a center trunnion.
- SMC will make appropriate arrangements if no dimension, tolerance, or finish instructions are given in the diagram.
- The possible range of trunnion bracket mounting position is indicated in the table below.
- Some trunnion mounting positions do not allow auto switch mounting. Please consult with SMC for more information.
- When the trunnion position is changed to somewhere close to the cover for the end lock cylinder, there is a possibility that the lock part and the trunnion pivot bracket may interfere with each other. Change the lock position (-X3) at the same time.
- The CS2 series has a greater range of trunnion bracket mounting positions than CS1 series, so the value of "Z + 1/2 stroke" at -XC14A and -XC14B is different.

MB Series

Bore size (mm)	Symbol	Z + 1/2 stroke (mm)					
		For -XC14A	For -XC14B	For -XC14		Reference Standard (Center trunnion)	Minimum stroke
				Minimum	Maximum		
32		82.5	95.5 + Stroke	84	94 + Stroke	89 + 1/2 stroke	1
40		89	97 + Stroke	90	96 + Stroke	93 + 1/2 stroke	1
50		100.5	109.5 + Stroke	102	108 + Stroke	105 + 1/2 stroke	1
63		103.5	106.5 + Stroke	105	105 + Stroke	105 + 1/2 stroke	1
80		127	131 + Stroke	128	130 + Stroke	129 + 1/2 stroke	1
100		130	128 + Stroke	131	127 + Stroke	129 + 1/2 stroke	1
125		160	154 + Stroke	160.5	153.5 + Stroke	157 + 1/2 stroke	1

CA2/CBA2/CVS1 Series

Bore size (mm)	Symbol	Z + 1/2 stroke (mm)					
		For -XC14A	For -XC14B	For -XC14		Reference Standard (Center trunnion)	Minimum stroke
				Minimum	Maximum		
40		89	97 + Stroke	89.5	96.5 + Stroke	93 + 1/2 stroke	1
50		99	107 + Stroke	99.5	106.5 + Stroke	103 + 1/2 stroke	1
63		103	111 + Stroke	103.5	110.5 + Stroke	107 + 1/2 stroke	1
80		125	133 + Stroke	125.5	132.5 + Stroke	129 + 1/2 stroke	1
100		132	138 + Stroke	132.5	137.5 + Stroke	135 + 1/2 stroke	1

CS1 Series

Bore size (mm)	Symbol	Z + 1/2 stroke (mm)					
		For -XC14A	For -XC14B	For -XC14		Reference Standard (Center trunnion)	Minimum stroke
				Minimum	Maximum		
125		170	148 + Stroke	170.5	147.5 + Stroke	159 + 1/2 stroke	25
140		172.5	145.5 + Stroke	173	145 + Stroke	159 + 1/2 stroke	30
160		189	157 + Stroke	189.5	156.5 + Stroke	173 + 1/2 stroke	35
180		203.5	177.5 + Stroke	204	177 + Stroke	190.5 + 1/2 stroke	30
200		203.5	177.5 + Stroke	204	177 + Stroke	190.5 + 1/2 stroke	30
250		243.5	217.5 + Stroke	244	217 + Stroke	230.5 + 1/2 stroke	30
300		263.5	232.5 + Stroke	264	232 + Stroke	248 + 1/2 stroke	35

Simple Specials: Change of Trunnion Bracket Mounting Position

Symbol
-XC14

CS2 Series

Bore size (mm)	Symbol		Z + 1/2 x Stroke				Minimum stroke
	For -XC14A	For -XC14B	For -XC14		Reference Standard (Center trunnion)		
			Minimum	Maximum			
125	165.5	152.5 + Stroke	166	152 + Stroke	159 + 1/2 x Stroke	25	
140	168	150 + Stroke	168.5	149.5 + Stroke	159 + 1/2 x Stroke	30	
160	186	160 + Stroke	186.5	159.5 + Stroke	173 + 1/2 x Stroke	35	

CNA2 Series

Bore size (mm)	Symbol		Z + 1/2 stroke				Minimum stroke
	For -XC14A	For -XC14B	Without rod boot		Reference Standard (Center trunnion)		
			Minimum	Maximum			
40	158	166 + Stroke	158.5	165.5 + Stroke	162 + 0.5 stroke	25	
50	177	185 + Stroke	177.5	184.5 + Stroke	181 + 0.5 stroke	25	
63	187	195 + Stroke	187.5	194.5 + Stroke	191 + 0.5 stroke	32	
80	227	235 + Stroke	227.5	234.5 + Stroke	231 + 0.5 stroke	41	
100	252	258 + Stroke	252.5	257.5 + Stroke	255 + 0.5 stroke	45	

CNS Series

Bore size (mm)	Symbol		Z + 1/2 stroke				Minimum stroke
	For -XC14A	For -XC14B	Without rod boot		Reference Standard (Center trunnion)		
			Minimum	Maximum			
125	375	353 + Stroke	375.5	352.5 + Stroke	364 + 1/2 stroke	25	
140	417.5	390.5 + Stroke	418	390 + Stroke	404 + 0.5 stroke	30	
160	479	447 + Stroke	479.5	446.5 + Stroke	463 + 0.5 stroke	35	
Bore size (mm)	Symbol		Z + ℓ + 1/2 stroke				Minimum stroke
	For -XC14A	For -XC14B	With rod boot		Reference Standard (Center trunnion)		
			Minimum	Maximum			
125	398 + ℓ	376 + ℓ + Stroke	398.5 + ℓ	375.5 + ℓ + Stroke	387 + ℓ + 1/2 stroke	30	
140	440.5 + ℓ	413.5 + ℓ + Stroke	441 + ℓ	413 + ℓ + Stroke	427 + ℓ + 1/2 stroke	30	
160	500 + ℓ	468 + ℓ + Stroke	500.5 + ℓ	467.5 + ℓ + Stroke	484 + ℓ + 1/2 stroke	35	

CLS Series

Bore size (mm)	Symbol		Z + 1/2 stroke				Minimum stroke
	For -XC14A	For -XC14B	Without rod boot		Reference Standard (Center trunnion)		
			Minimum	Maximum			
125	280	258 + Stroke	280.5	257.5 + Stroke	269 + 0.5 stroke	25	
140	282.5	255.5 + Stroke	283	255 + Stroke	269 + 0.5 stroke	30	
160	321	289 + Stroke	321.5	288.5 + Stroke	305 + 0.5 stroke	35	
Bore size (mm)	Symbol		With rod boot				Minimum stroke
	For -XC14A	For -XC14B	For -XC14		Reference Standard (Center trunnion)		
			Minimum	Maximum			
125	303 + 0.2 stroke	281+1.2 stroke	303.5 + 0.2 stroke	280.5 + 1.2 stroke	292 + 0.7 stroke	25	
140	305.5 + 0.2 stroke	278.5+1.2 stroke	306 + 0.2 stroke	278 + 1.2 stroke	292 + 0.7 stroke	30	
160	345 + 0.2 stroke	310+1.2 stroke	345.5 + 0.2 stroke	309.5 + 1.2 stroke	326 + 0.7 stroke	35	

CL1 Series

Bore size (mm)	Symbol		Z + 1/2 stroke				Minimum stroke
	For -XC14A	For -XC14B	Without rod boot		Reference Standard (Center trunnion)		
			Minimum	Maximum			
40	158	166 + Stroke	158.5	165.5 + Stroke	162 + 1/2 stroke	—	
50	177	185 + Stroke	177.5	184.5 + Stroke	181 + 1/2 stroke	—	
63	187	195 + Stroke	187.5	194.5 + Stroke	191 + 1/2 stroke	—	
80	217	225 + Stroke	217.5	224.5 + Stroke	221 + 1/2 stroke	—	
100	232	238 + Stroke	232.5	237.5 + Stroke	235 + 1/2 stroke	—	
Bore size (mm)	Symbol		Z + ℓ + 1/2 stroke				Minimum stroke
	For -XC14A	For -XC14B	With rod boot		Reference Standard (Center trunnion)		
			Minimum	Maximum			
40	166 + ℓ	174 + ℓ + Stroke	166.5 + ℓ	173.5 + ℓ + Stroke	170 + ℓ + 1/2 stroke	20	
50	185 + ℓ	193 + ℓ + Stroke	185.5 + ℓ	192.5 + ℓ + Stroke	189 + ℓ + 1/2 stroke	20	
63	195 + ℓ	203 + ℓ + Stroke	195.5 + ℓ	202.5 + ℓ + Stroke	199 + ℓ + 1/2 stroke	20	
80	226 + ℓ	234 + ℓ + Stroke	226.5 + ℓ	233.5 + ℓ + Stroke	230 + ℓ + 1/2 stroke	20	
100	241 + ℓ	247 + ℓ + Stroke	241.5 + ℓ	246.5 + ℓ + Stroke	244 + ℓ + 1/2 stroke	20	



Simple Specials: -XC15: Change of Tie-rod Length

These changes are dealt with Simple Specials System. Refer to the front matter pages for details.

Symbol

-XC15

9 Change of Tie-rod Length

Cylinder with M dimension for tie-rod length changed from the standard length.

Series	Description	Model	Action	Note
CA2	Standard type	CA2-Z	Double acting, Single rod	
		CA2W-Z	Double acting, Double rod	
	Non-rotating rod type	CA2K	Double acting, Single rod	Applicable to ø40 to ø63
		CA2KW	Double acting, Double rod	Applicable to ø40 to ø63
	Air-hydro cylinder	CA2H	Double acting, Single rod	
	End lock cylinder	CBA2	Double acting, Single rod	
Smooth cylinder	CA2Y-Z	Double acting, Single rod		
CS1	Standard type	CS1	Double acting, Single rod	
		CS1W	Double acting, Double rod	
CS2	Standard type	CS2	Double acting, Single rod	
		CS2W	Double acting, Double rod	
CNA2	Cylinder with lock	CS1□Q	Double acting, Single rod	
		CS2Y	Double acting, Single rod	
CV	Valve mounted cylinder	CNA2	Double acting, Single rod	
		CNA2W	Double acting, Double rod	
		CV3	Double acting, Single rod	
		CV3K	Double acting, Single rod	Applicable to ø40 to ø63
		CVS1	Double acting, Single rod	
CVS1K	Double acting, Single rod	Applicable to ø40 to ø63		

CA2, CNA2, CV series

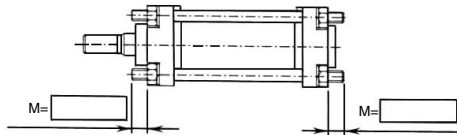

CS1, CS2 series

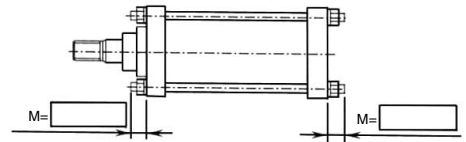

⚠ Precautions

- To order, specify the M dimension as well as the part number.
- SMC will make appropriate arrangements if no dimension, tolerance, or finish instructions are given in the diagram.
- Tie-rod length changeable range is described in the below.
- The M dimension of the bracket mounting side of Flange (F, G), Clevis (C, D) types cannot be specified.

Tie-rod Length Changeable Range

(mm)

Model	CA2, CNA2, CV	CS1						
Bore size (mm)	All bore size	125	140	160	180	200	250	300
M Min.	0	15.5	18	20.5	22	26	32.5	
M Max.	300 ⁽¹⁾	270						

Note 1) The maximum value of M on the rod side for the CNA2 series is 50.

Tie-rod Length Changeable Range

(mm)

Model	CS2					
Bore size (mm)	125		140		160	
Mounting bracket	L	B, F, G, C, D, T	L	B, F, G, C, D, T	L	B, F, G, C, D, T
M Min.	20	12	21	12	23	14
M Max.	270					

Simple Specials: -XC79: Tapped Hole, Drilled Hole, Pinned Hole Machined Additionally

These changes are dealt with Simple Specials System. Refer to the front matter pages for details.

10 Tapped Hole, Drilled Hole, Pinned Hole Machined Additionally

Symbol

-XC79

This simple special is meant for machining additionally tapped hole, drilled hole, and pinned hole, as requested from customer, on parts designed largely for mounting a workpiece, etc. in the combined air cylinders.

But, for each model, since they have the portions which are impossible to machine additionally, refer to the additional machining limitation.

Applicable Series

Series			Action
MGP	Standard type	MGP-Z	Double acting
	With air cushion	MGP-A-Z	Double acting
	With end lock	MGP-H/R	Double acting
	High precision ball bushing type with end lock	MGP-A-H/R	Double acting
MGQ	Standard type	MGQ	Double acting
MLGP	With lock	MLGP	Double acting

Series			Action
MVGQ	With valve	MVGQ	Double acting
MGG	Standard type	MGG	Double acting
	With end lock	MGG-H/R	Double acting
MGC	Compact type	MGC	Double acting
MLGC	Compact type with lock	MLGC	Double acting
MGF	Standard type	MGF	Double acting
MXH	Standard type	MXH-Z	Double acting

Applicable Series and Component Parts Machined Additionally

Applicable series	Component parts applicable for additional machining
MGP, MGQ, MLGP, MVGQ	Plate
MGG, MGC, MLGC	Front plate
MGF	Plate (Upper plate only)
MXH	Table

⚠ Precautions

- We cannot take any responsibility as for the intensity of holes machined additionally and the effects of decreased intensity for the product itself.
- It will not be plated again for the machined part additionally.
- Be sure to fill in "through" for through-hole, and "effective depth" for blind hole.
- When using by machining through-hole additionally, ensure that the tip of the bolt, etc. for mounting workpiece should not stick into the cylinder side. It may result in an unexpected problem.
- Use caution not to interfere the current mounting hole on the standard products with the hole to be machined additionally. But it is possible to drill additionally the larger size of hole at the same position as the current hole.

Common Complementary Explanation/Holes which can be additionally machined are the following 3 types.

Tapped hole	Drilled hole	Pinned hole												
<p>Designated nominal diameter and tapped hole of a pitch are machined additionally. (Maximum nominal thread diameter M20)</p> <p>Blind hole is deep into the bottom of prepared hole which sums up A to C in the figure below in contrast to the effective depth of tapped hole. When there is a condition which does not allow through-hole, etc., leave sufficient thickness in the inner part of hole.</p> <p style="text-align: center;">D (Thread size)</p> <p style="text-align: center;">A (Effective thread depth)</p> <p style="text-align: center;">B = 3 x P (Incomplete thread section)</p> <p style="text-align: center;">C = 0.3 x (D - P)</p> <p>Note) P stands for thread pitch.</p>	<p>Drilled hole of a designated internal diameter is machined. (Maximum hole diameter 20 mm)</p> <p>If you wish for blind hole, instruct us with effective depth. (Refer to the figure below.) Besides, dimensional accuracy for internal diameter will be ± 0.2 mm.</p> <p style="text-align: center;">D</p> <p style="text-align: center;">A (Effective depth)</p> <p style="text-align: center;">C = 0.3D</p>	<p>Pinned hole of a designated diameter (reamer hole) is machined. (Maximum hole diameter 20 mm)</p> <p>Internal dimension tolerates H7 tolerance to the designated hole diameter. (Refer to the table below.)</p> <table border="1" style="width: 100%; text-align: center;"> <thead> <tr> <th>Hole dia.</th> <th>3 or less</th> <th>Over 3 to 6</th> <th>Over 6 to 10</th> <th>Over 10 to 18</th> <th>Over 18 to 20</th> </tr> </thead> <tbody> <tr> <td>Tolerance</td> <td>+0.01 0</td> <td>+0.012 0</td> <td>+0.015 0</td> <td>+0.018 0</td> <td>+0.021 0</td> </tr> </tbody> </table> <p style="text-align: center;">D_{H7}</p> <p style="text-align: center;">A (Effective depth)</p>	Hole dia.	3 or less	Over 3 to 6	Over 6 to 10	Over 10 to 18	Over 18 to 20	Tolerance	+0.01 0	+0.012 0	+0.015 0	+0.018 0	+0.021 0
Hole dia.	3 or less	Over 3 to 6	Over 6 to 10	Over 10 to 18	Over 18 to 20									
Tolerance	+0.01 0	+0.012 0	+0.015 0	+0.018 0	+0.021 0									

Simple Specials:

-XC79: Tapped Hole, Drilled Hole, Pinned Hole Machined Additionally

These changes are dealt with Simple Specials System. Refer to the front matter pages for details.

10 Tapped Hole, Drilled Hole, Pinned Hole Machined Additionally

Limitation for Machining Additionally/Since the slanted lines denote the restricted range for machining additionally, design the dimensions, referring to below.

MGP/MLGP series

Plate material: Steel

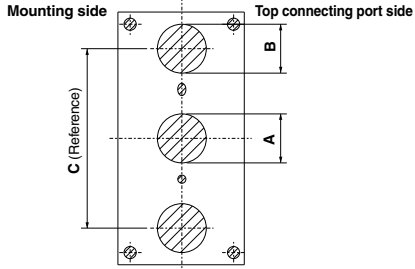

Dimensional Range Not Possible to Machine Additionally (mm)

Bore size (mm)	A	B	C
12	8	11	41
16	10	13	46
20	12	15	54
25	14	21	64
32	25	25	78
40	25	25	86
50	30	30	110
63	30	30	124
80	34	34	156
100	42	42	188

MGQ/MVGQ series

Plate material: Steel

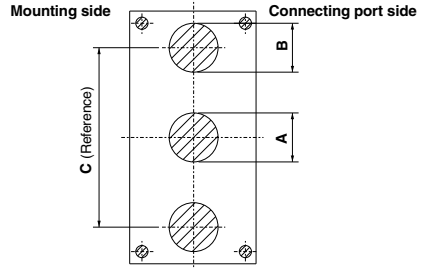

Dimensional Range Not Possible to Machine Additionally (mm)

Bore size (mm)	A	B	C
12	8	11	36
16	10	13	38
20	12	15	46
25	14	21	56
32	25	25	80
40	25	25	90
50	30	30	100
63	30	30	110
80	34	34	140
100	42	42	170

MGG series

Front plate material: Steel

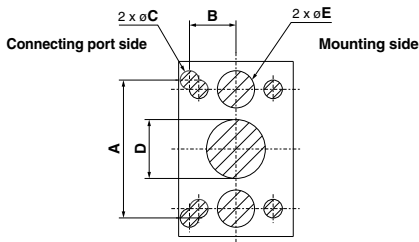

Dimensional Range Not Possible to Machine Additionally (mm)

Bore size (mm)	A	B	C	D	E
20	70	17.5	9	24	12.5
25	85	20	13	31	13
32	91	23	13	31	19
40	114	29	19	36	23
50	132	34	19	44	29
63	156	38	19	44	30
80	186	44	26	58	35
100	214	49	26	64	40

MGC/MLGC series

Front plate material: Steel

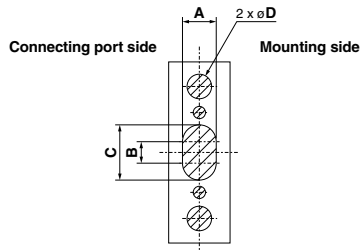

MGC Dimensional Range Not Possible to Machine Additionally (mm)

Bore size (mm)	A	B	C	D
20	18	10	28	12.5
25	23	13	36	12.5
32	23	13	36	19
40	27	15	42	23
50	33	19	52	28

MLGC Dimensional Range Not Possible to Machine Additionally (mm)

Bore size (mm)	A	B	C	D
20	18	10	28	16
25	23	13	36	20
32	23	13	36	20
40	27	15	42	25

Simple Specials: Tapped Hole, Drilled Hole, Pinned Hole Machined Additionally

Symbol
-XC79

Limitation for Machining Additionally Since the slanted lines denote the restricted range for machining additionally, design the dimensions, referring to below.

MGF series

Top plate material: Aluminum

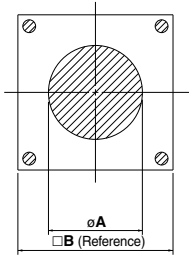

Connecting port side

Dimensional Range Not Possible to Machine Additionally (mm)

Model	A	B
MGF40	90	120
MGF63	120	160
MGF100	160	200

MXH series

Table material: Aluminum

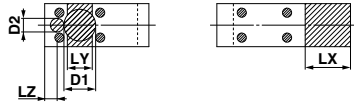

Dimensional Range Not Possible to Machine Additionally (mm)

Model	D1	D2	LY	LX	LZ
MXH6	11	5.8	9	20	5.5
MXH10	14	6	11	22	6.5
MXH16	18	7.5	16	29	6.5
MXH20	22	9.7	22	32	7